

TE SERIES

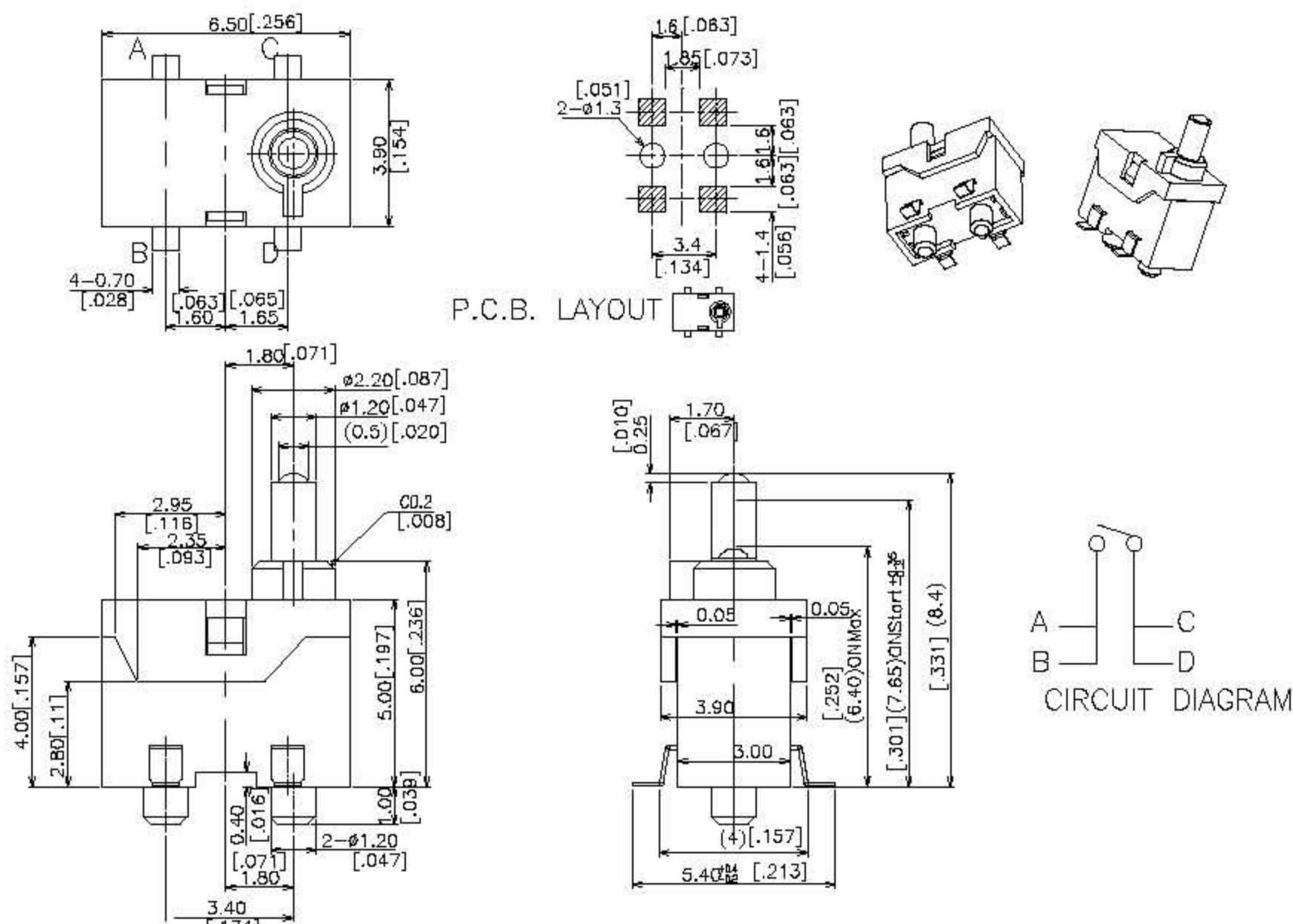

DIMENSIONS

TE-M



General Tolerance : $\pm 0.2\text{mm}$

TE-ML

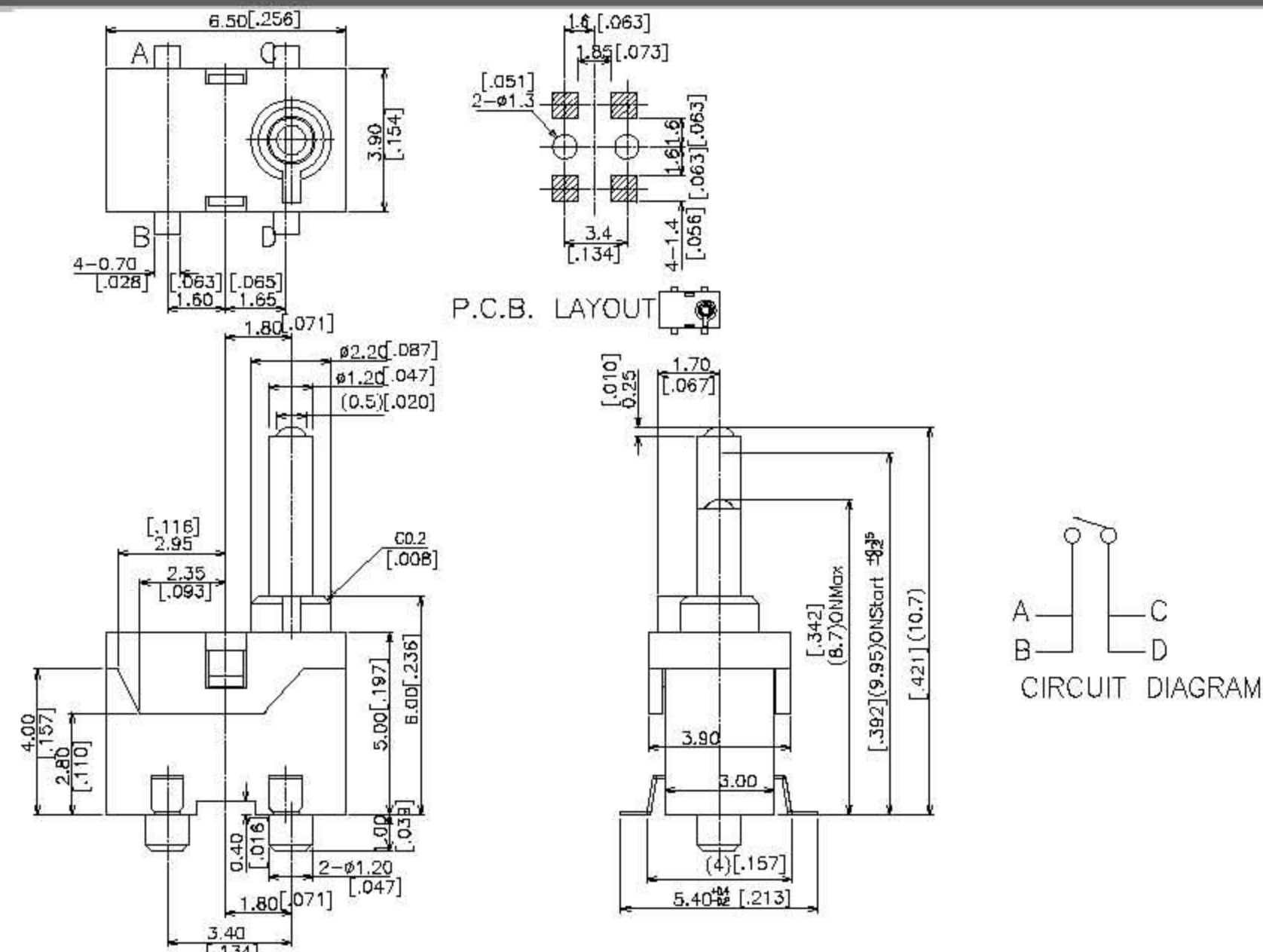

General Tolerance : $\pm 0.2\text{mm}$

TE-H

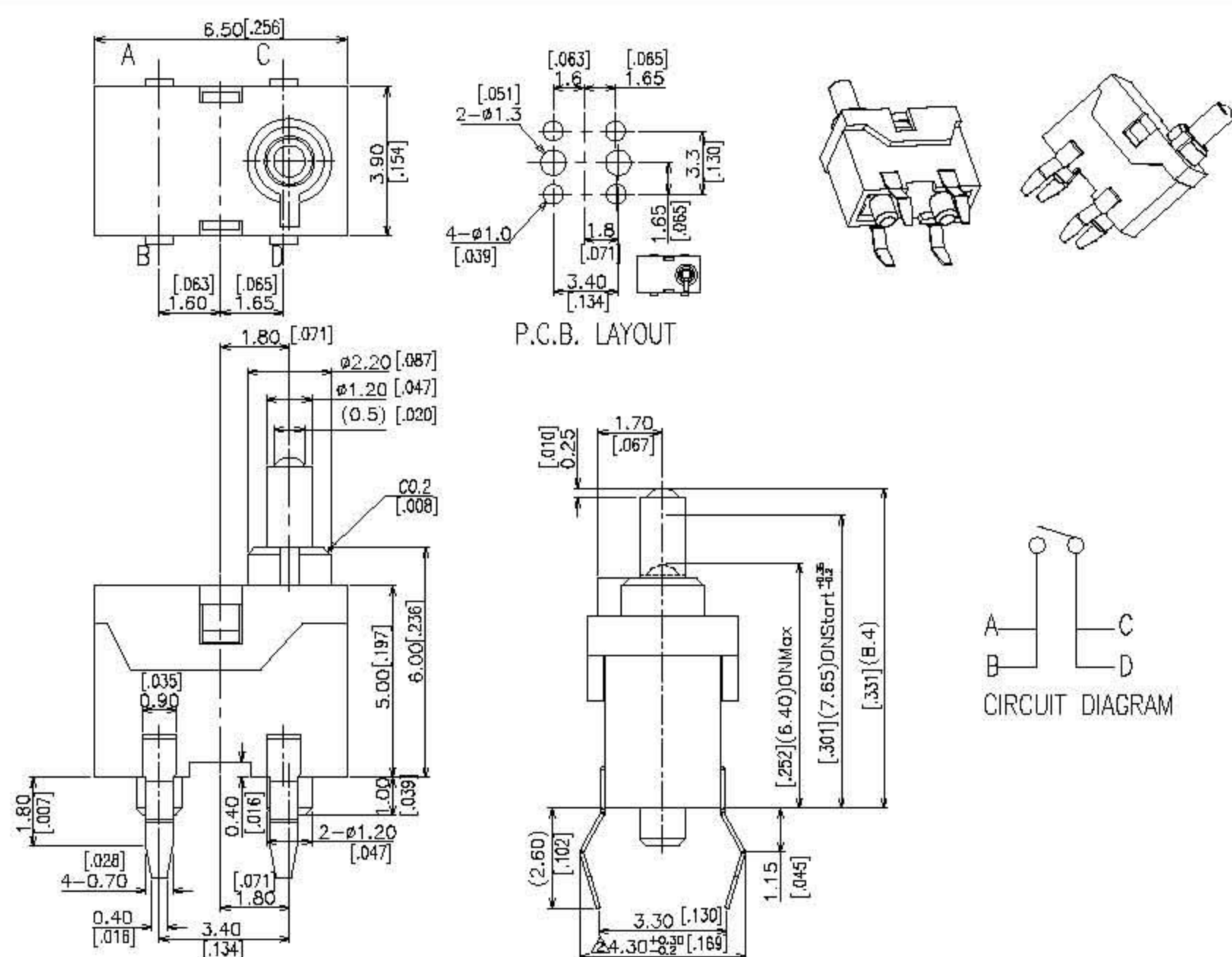

General Tolerance : 0.2mm

TE-HL

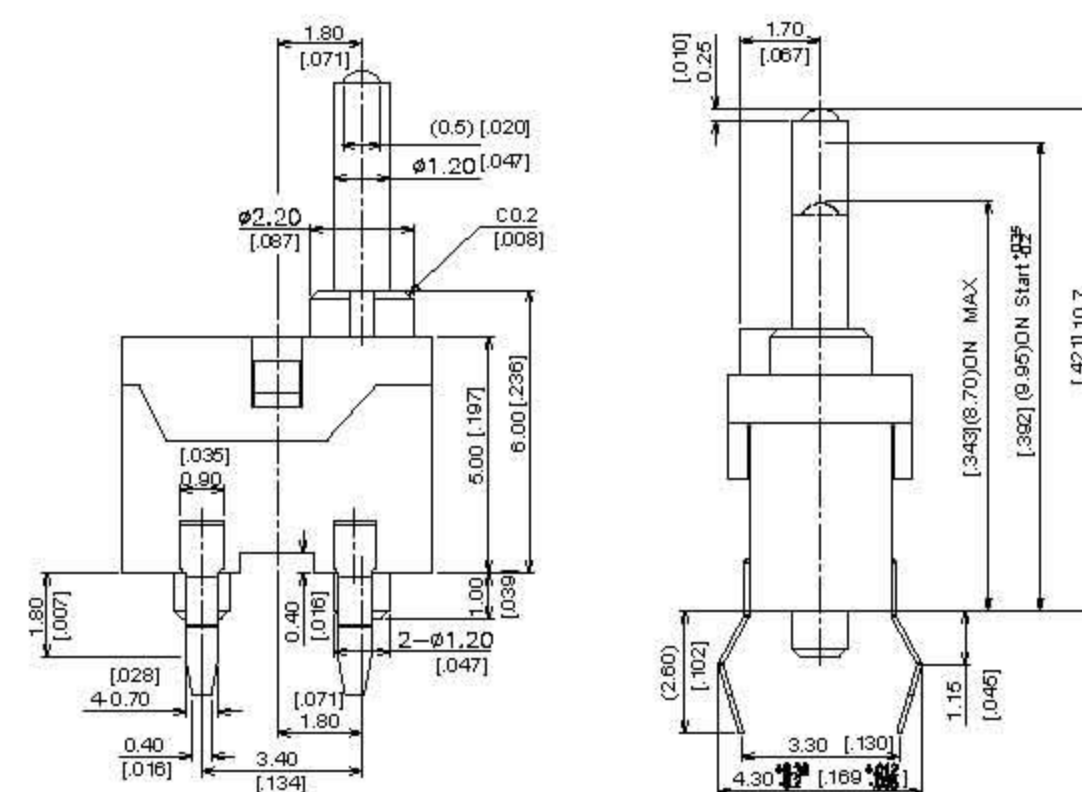

HOW TO ORDER

TE - □ - □ - □ - □

Package Style:
T/R=Tape & Reel [only TE-M, TE-ML]
□ = Tube

Soldering:
V=Lead Free Solderable

Total Height:
L = 10.7mm
□ = 8.4mm

Terminal Type
M = SMT Terminals
H = Through Hole Type

Detector Switch

SPECIFICATION

△MECHANICAL

Operation Force: 30gf max.

Stroke: 2 mm

Operation Temperature: -20°C to +70°C

Storage Temperature: -30°C to +80°C

△ELECTRICAL

Electrical Life: 50,000 cycles

Rating: 5mA, 5VDC

Contact Resistance: 500MΩ max.

Insulation Resistance: 100MΩ min. at 250VDC

Dielectric Strength: 250VAC/ minute

Contact Arrangement: SPST

Contact Arrangement: 1pole 1throw

MATERIAL

△COVER: UL 94V-0 LCP High-temp thermoplastic
Color: Black

△BASE: UL 94V-0 LCP High-temp thermoplastic
Color: Black

△CONTACT DISC: Stainless steel with silver cladding

△TERMINAL: Phosphor bronze with silver plated

SOLDERING PROCESS

For best results, please follow these recommend conditions :

△HAND SOLDERING : Use a soldering iron of 30 watts,
controlled at 608°F(320°C) approximately 2 seconds.

△WAVE SOLDERING: Recommended solder temperature
at 500°F (260°C) max. 5 seconds for through hole type.

△REFLOW SOLDERING: When applying reflow soldering,
the peak temperature or the reflow oven should be set
at 260°C max.

△Make sure that there is no flux rise on the surface of
The PCB.

△Reflow Temperature Profile:

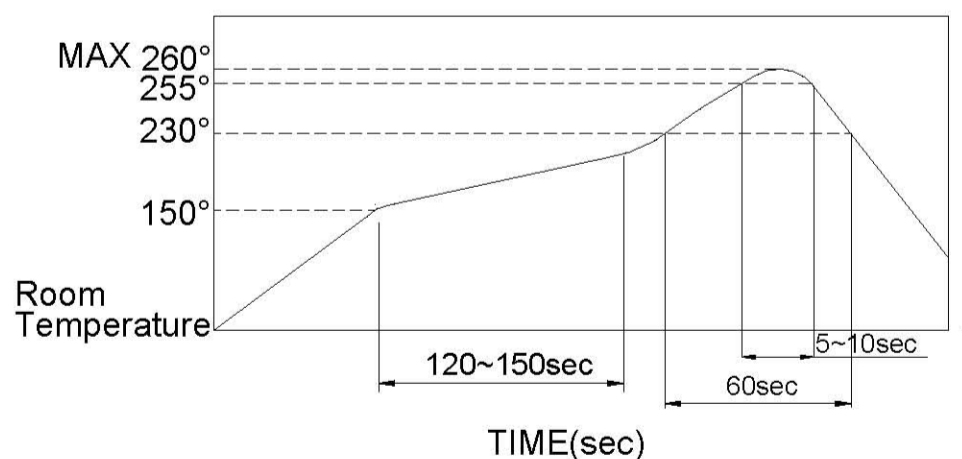

PACKING

Part Number	Number Per Tube	Number Per Reel
TE-M	72	500
TE-H	72	-
TE-ML	-	400

TE-M REEL

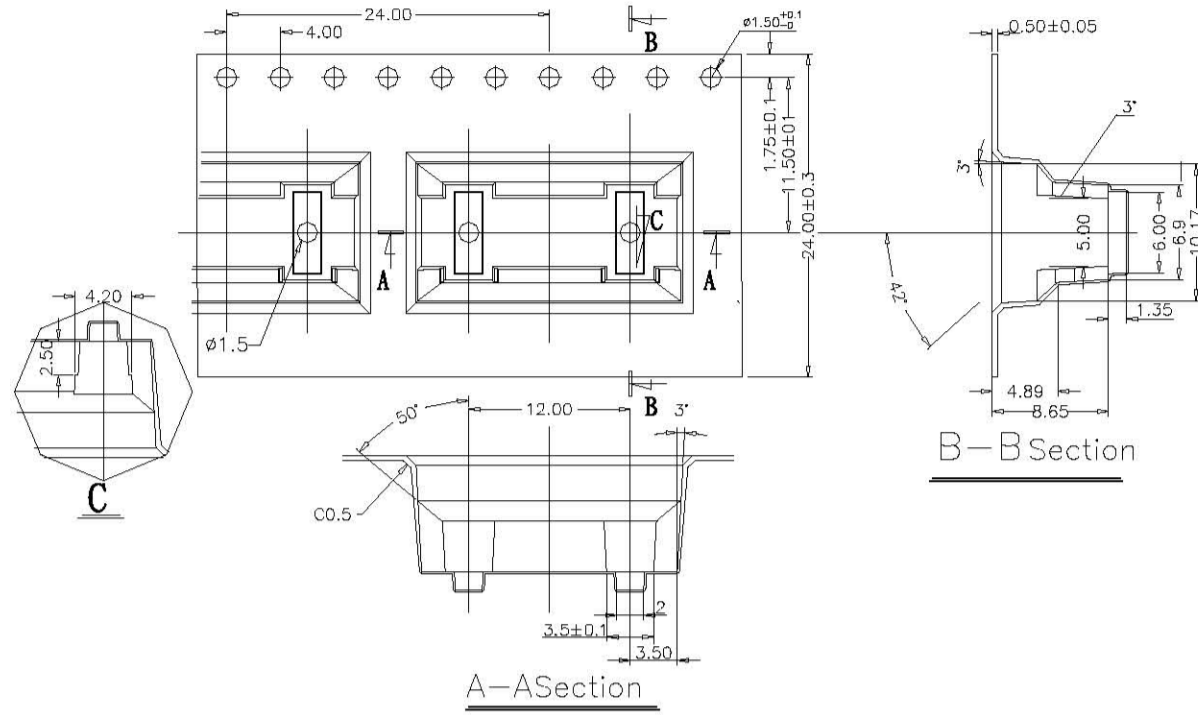

General Tolerance : $\pm 0.1\text{mm}$

TE-ML REEL

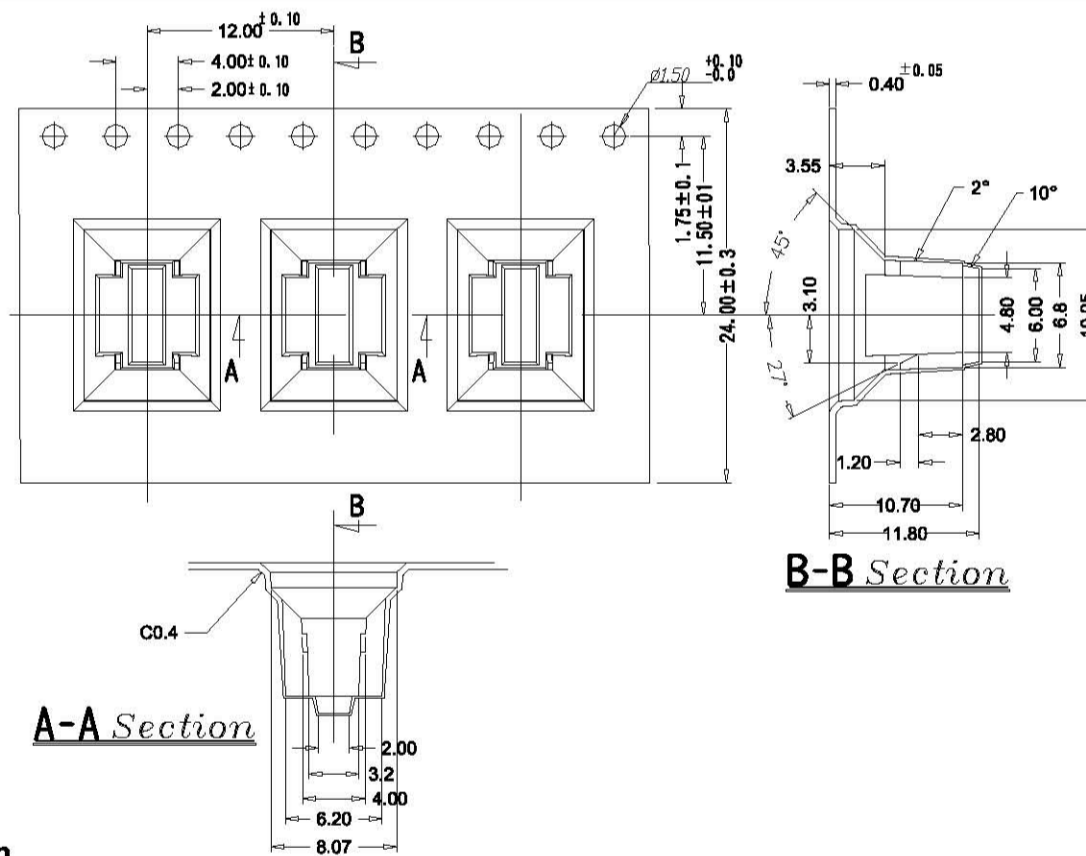

General Tolerance : $\pm 0.1\text{mm}$

TUBE

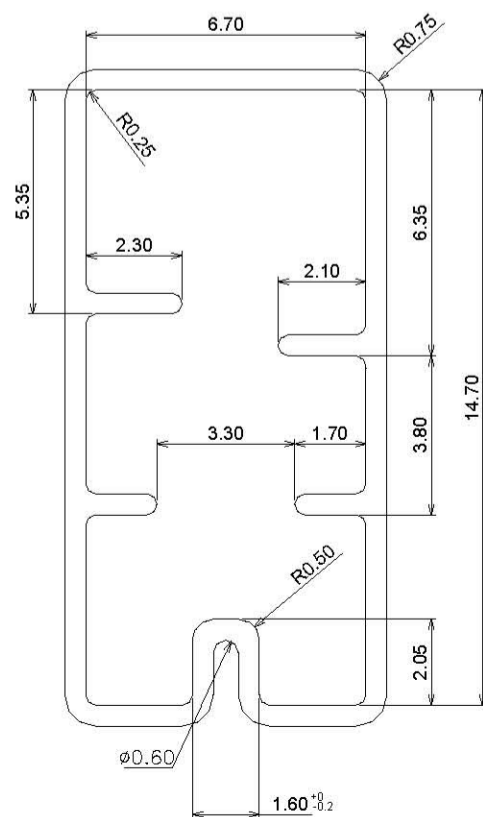

General Tolerance : $\pm 0.2\text{mm}$